

# Low Pressure Sensor

CE

Model PR-274/275

RoHS



- 100% solid-state, micro-machined glass-on-silicon, ultra-stable capacitance sensor
- As low as  $\pm 0.05$ " wc ( $\pm 12.5$  pa)
- Can resolve less than  $0.00001$ " wc ( $0.00025$  pa)
- Up to 10 PSID overpressure without zero shift
- Up to 6 field selectable ranges in one unit
- Wide 12-40 VDC/12-35 VAC unregulated supply voltage
- Two temperature compensated output versions, 4-20 mA 2-wire or field selectable 0-5 VDC/0-10 VDC
- Non-interacting zero and span trimmers
- NIST traceable calibration
- Two rugged steel enclosure types NEMA 4 (IP-65) or panel mount for ease of installation
- Conforms to EMC and RoHS standards

The PR-274/275 incorporates a new micro-machined glass-on-silicon (GI-Si) capacitance sensor. This technology revolutionizes very low pressure measurement. Temperature related zero drift, calibration shift due to overpressure, non-repeatability, non-linearity, and extremely low pressure sensitivity have been some of the problems which have plagued the controls industry. The PR-274/275 with the new GI-Si technology not only addresses all of the above shortcomings, but for the first time offers a reliable, accurate means to measure and control building/room pressure, air flow, duct pressure, filter pressure drop, or any other extremely low pressure application. Up to six field selectable direct or compound ranges, two enclosure types, field selectable outputs, fully temperature compensated NIST traceable accuracy, non-interacting zero and span adjustments, short circuit and reverse polarity protected output, and a liberal five year warranty are some of the features which make the PR-274/275 the industry's highest performance, ultra-stable, low pressure sensor.

**MAMAC SYSTEMS®**

## PR-274/275

The PR-274/275 incorporates sophisticated integrated circuits to not only provide a high level, fully-conditioned and temperature compensated output, but also to offer field selectable flexibility which was unheard of in the industry. The PR-274/275 offers up to six field selectable pressure ranges in one unit. In this way, a customer does not need to know the exact pressure range prior to selection. By merely knowing the application, a unit may be selected and then later field-configured for the desired pressure range. With fixed range units, in case of engineering error or incorrect selection, the only solution is expensive field recalibration or time consuming product exchange or replacement. Similarly, numerous units have to be kept in stock as spares to cover all ranges in case of field failure. The PR-274/275 with the field selectable pressure range feature, eliminates above mentioned costly inefficiencies. A single unit can be configured to cover all the pressure ranges in a particular application thereby eliminating any possibility of incorrect range selection. Additionally, one unit can be kept in stock and, in the event of failure, it can be field-configured thereby eliminating the need to stock numerous fixed range units. (For a complete listing of all ranges available, please see the ordering information section on page three.)

On VDC output units, two additional field-selectable options are available: dual outputs 0-5 or 0-10 VDC, and dual unregulated supply voltages 12-35 VAC or 12-40 VDC. By merely setting a dip switch, one can select the desired output for the specific application. As far as supply voltage is concerned, the unit automatically configures for AC or DC, and no field selection is necessary. Another feature is that the output is fully protected from short circuit to ground, or if the supply voltage is applied by mistake to the output. Past experience demonstrates that field-related wiring problems do occur. Instead of denying this fact, the protection circuit is designed in to ensure trouble-free start-up. The VDC output unit is also designed to handle low impedance circuits. In fact, the unit can drive up to 1k ohms minimum. In this way, multiple controllers, indicators, or other devices can be paralleled to the output without performance degradation.

The mA output units can function over a wide

unregulated supply voltage range: 12-40 VDC without any effect on calibration or performance. The unit has built-in reverse polarity protection. As a result, it is next to impossible to damage the unit by miswiring. By using sophisticated low drop-out voltage regulators and CMOS integrated circuits, the mA output unit can drive very high output impedance.

In fact, with only 12 VDC supply, the unit can drive 200 ohms. At 40 VDC, the unit is capable of handling up to 1600 ohms load. In this way, the output loop can be tied in series to multiple controllers, indicators, and other devices without degrading the performance.

Due to the low mass of the micro-machined capacitance Gl-Si sensor, the mounting orientation error for ranges higher than 1.0"wc (250 pa) is negligible. For extremely low ranges, if the unit is installed as indicated on the label, there should be no orientation error. However, due to space limitation, if the unit cannot be installed in the indicated position, the error can be easily removed by merely adjusting the zero trimmer. Since the zero and span trimmers are non-interactive, adjustment to the zero should under no circumstance affect the calibration integrity of the unit including linearity and repeatability specifications across the range.

The PR-274/275 is available with two packaging options: a NEMA 4 (IP-65) fully gasketed, dust proof and splash proof enclosure, or a lightweight but rugged panel mount chassis for ease of installation with minimum space requirement in a control panel. The NEMA 4 (IP-65) enclosure has an external mounting bracket to facilitate field installation. A ½" (.875"/22.25mm dia.) knock-out for conduit connection is also provided. A liquid tight cable connector is also supplied if the unit is not being hard wired. Once installed, the enclosure maintains its environmental rating and protects the electronics and the sensing element from condensation, corrosive contaminants and other environmental pollutants. Both packaging options also have additional features for ease of installation, including upluggable terminal blocks, rugged brass hose barbs, easily accessible zero and span trimmers, and conveniently located dip switches for field selection.

# PR-274/275

## SPECIFICATIONS:

**Accuracy\*:** ±1% FS

**Overpressure:** 10 PSID

**Supply Voltage:** 12-40 VDC  
12-35 VAC (VDC output units only)

**Supply Current:** VDC Units – 10 mA max.  
mA Units – 20 mA max.

**Compensated Temp Range:** 25°F - 150°F  
(-4°C - 65°C)

**T.C. Error:** ±0.0125%/°F (.02%/°C)

**Load Impedance:** 1.6K ohms max. at 40 VDC  
(mA output units)  
1K ohms min.  
(VDC output units)

**Enclosure:** 18 Ga. C. R. Steel NEMA 4 (IP-65)  
or Panel Mount Chassis

**Finish:** Baked-on enamel – PMS2GR88B

*\*Includes non-linearity, hysteresis, and non-repeatability*

**Operating Temp Range:** 0°F – 175°F  
(-18°C – 80°C)

**Media Compatibility:** Clean dry air or any inert gas

**Environmental:** 10–90%RH Non-Condensing

**Termination:** Unpluggable screw terminal block

**Wire Size:** 12 Ga. max

**Weight:** Enclosure - 1.0 lbs. (.45 kg)  
Panel Mount - 0.5 lbs. (.25 kg)

## CONFORMANCE & TESTING:

**RoHS Compliant**

**EMC Testing:**

BS EN 55022:1998, BS EN 55024:1998,  
EN 61000-3-3, EN 61000-4-2,  
EN 61000-4-3, EN 61000-4-4,  
EN 61000-4-5, EN 61000-4-6,  
EN 61000-4-11

## ORDERING INFORMATION: PR-

Packaging	Range	Output
<b>274</b> (enclosure)	<b>R1</b> ("wc) 0 to 0.10 / -0.05 to +0.05	<b>mA</b> (4-20 mA 2-wire)
<b>275</b> (panel mount)	<b>R2</b> ("wc) 0 to 1.0 / 0 to 0.5 / 0 to 0.25 / -0.5 to +0.5 / -0.25 to +0.25 / -0.125 to +0.125	<b>VDC</b> (0-5 VDC or 0-10 VDC field selectable)
	<b>R3</b> ("wc) 0 to 5.0 / 0 to 2.5 / 0 to 1.25 / -2.5 to +2.5 / -1.25 to +1.25 / -0.625 to +0.625	
	<b>R4</b> ("wc) 0 to 30 / 0 to 15 / 0 to 7.5 / -15.0 to +15.0 / -7.5 to +7.5 / -3.75 to +3.75	
	<b>R5*</b> (pa) 0 to 25 / -12.5 to +12.5	
	<b>R6*</b> (pa) 0 to 250 / 0 to 125 / 0 to 62.5 / -125 to +125 / -62.5 to +62.5 / -31.25 to +31.25	
	<b>R7*</b> (pa) 0 to 1250 / 0 to 625 / 0 to 312.5 / -625 to +625 / -312.5 to +312.5 / -156.25 to +156.25	
	<b>R8*</b> (pa) 0 to 7500 / 0 to 3750 / 0 to 1875 / -3750 to +3750 / -1875 to +1875 / -937.5 to +937.5	

**Example: PR-274-R2-mA:** Enclosure unit with R2 Range which has six (6) field selectable range options and 4-20 mA output.

**CAUTION: Do not use in explosive/hazardous environment or with flammable/combustible media.**

# PR-274/275

## Panel Mount

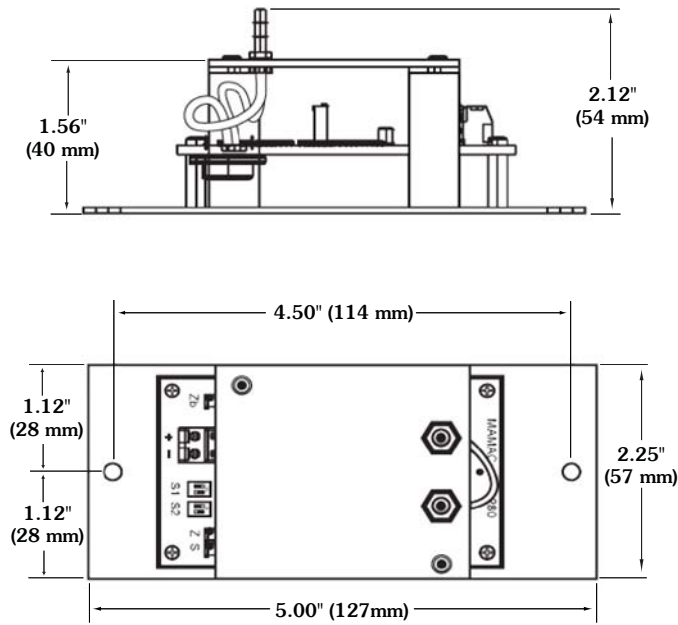

## Enclosure

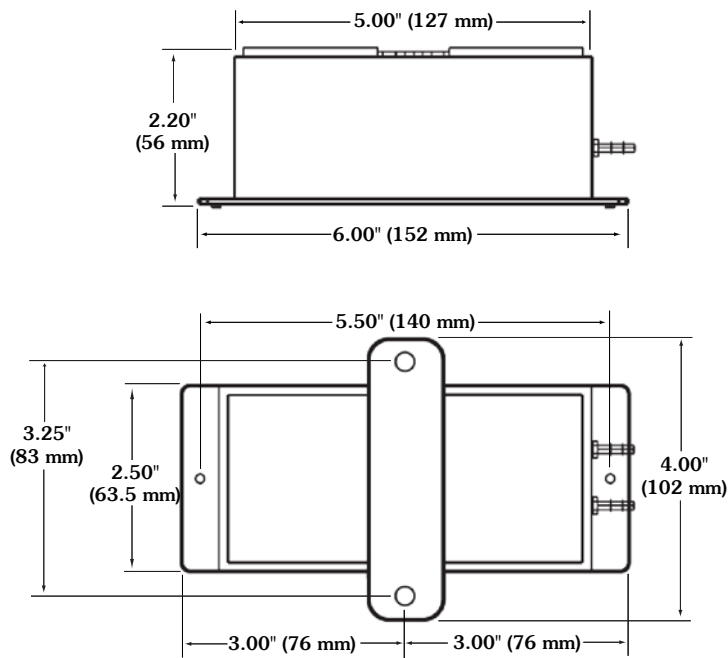



**MAMAC Systems is the leading global manufacturer of sensors, transducers, control peripherals and web browser based IP appliances. MAMAC products are used for HVAC and environmental controls, remote monitoring, alarming, energy metering and industrial automation.**

**All MAMAC products are manufactured in the USA.**

**WARRANTY:** MAMAC Systems, Inc. and its subsidiaries (hereinafter referred to as MAMAC Systems) warrants its products to be free of defects in material and workmanship for a period of five (5) years from date of shipment. If a unit is malfunctioning, it must be returned to the factory for evaluation. A return authorization number (RMA) will be issued by the customer service department and this number must be written or prominently displayed on the shipping boxes and all related documents. The defective part should be shipped freight pre-paid to the factory. Upon examination by MAMAC Systems, if the unit is found to be defective, it will be repaired or replaced at no charge to the customer. However, this warranty is void if the unit shows evidence of being tampered with, damaged during installation, misapplied, misused, or used in any other operating condition outside of the unit's published specifications.

**MAMAC Systems makes no other warranties or representations of any kind whatsoever, expressed or implied, except that of title. All implied warranties including any warranty of merchantability and fitness for a particular purpose are hereby disclaimed. User is responsible to determine suitability for intended use.**

**LIMITATIONS OF LIABILITY:** The remedies of buyer set forth herein are exclusive and the total liability of MAMAC Systems with respect to this order, whether based on contract, warranty, negligence, indemnification, strict liability or otherwise, shall not exceed the purchase price of the product upon which liability is based. **In no event shall MAMAC Systems be liable for consequential, incidental or special damages.** MAMAC Systems reserves the right to change any specifications without notice to improve performance, reliability, or function of our products.

Every precaution for accuracy has been taken in the preparation of this manual, however, MAMAC Systems neither assumes responsibility for any omissions or errors that may appear nor assumes liability for any damages that result from the use of the product in accordance with the information contained in the manual.

